

Creating an innovative vision for emergency power
battery diagnosis & monitoring technologies

iPQMS/BDS BDS/pro IBEX-series

All-In-One Solution
High Precision and Reliability
Realizing the Highest Economy
Precise Measurement Everywhere
Meeting all IEEE Std.
Comprehensive diagnosis software and Report package



iPQMS/BDS

intelligent Power Quality Monitoring System

- 55cells ~ Max. 448cells
- Suitable to Control power, large sized UPS
- Diagnosis and Reporting Software:
Centroid Web 2008 or Centroid 2005



BDS/pro

Battery Diagnostic System

- 12/24cells ~ 48cells
- Suitable to telecom, small/medium sized UPS
- Diagnosis and Reporting Software:
Centroid Web 2008 or Centroid 2005



IBEX-series

Intelligent Battery EXaminer

- Measure intercell and terminal post resistance
- The world's first compact design
- Diagnosis and Reporting Software:
Exmons Pro 2005 / 2008

New Leader in Future Technology

POWERTRON
POWERTRON ENGINEERING CO., LTD.

iPQMS/BDS

intelligent Power Quality Monitoring System
Battery Diagnostic System

iPQMS/BDS

iPQMS/BDS monitors and analyzes the status of stationary battery system such as voltage and current of emergency power supply power lines, charging and discharging DC voltage and current, cell voltage, temperature, internal ohmic measurement with the high accuracy in 24 hours of 365 days and TCP/IP environment, using any communication methods selected by the customer, as well as the early deterioration signs using internal ohmic measurements with any backup batteries in most critical applications. It is an "intelligent Power Quality Monitoring Systems" to ensure the integrity of your power backup system and offers the most comprehensive diagnosis software and reporting package.

We are sure that iPQMS/BDS exactly meets all IEEE Std. recommendations and will be the most reliable systems for diagnosis and monitoring of all stationary applications.

System Composition

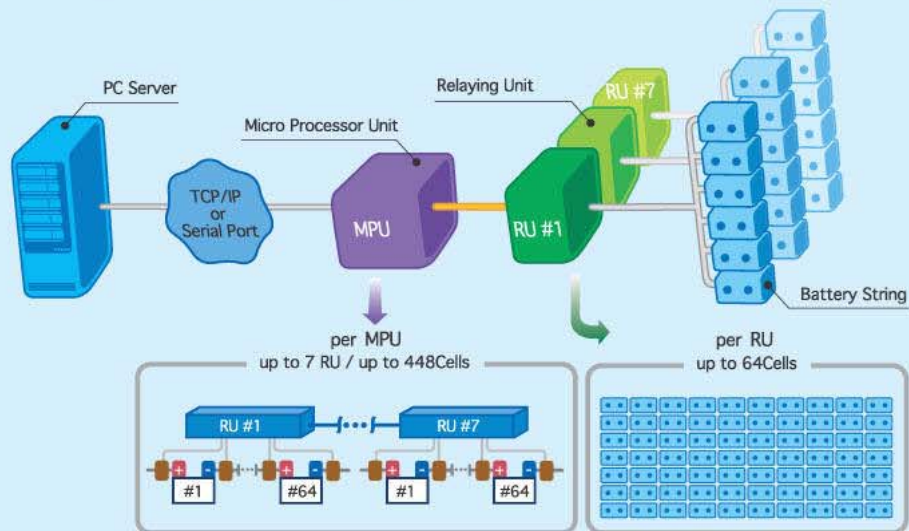

Comparison of connection points between Powetron's and the other products Battery Monitoring System.

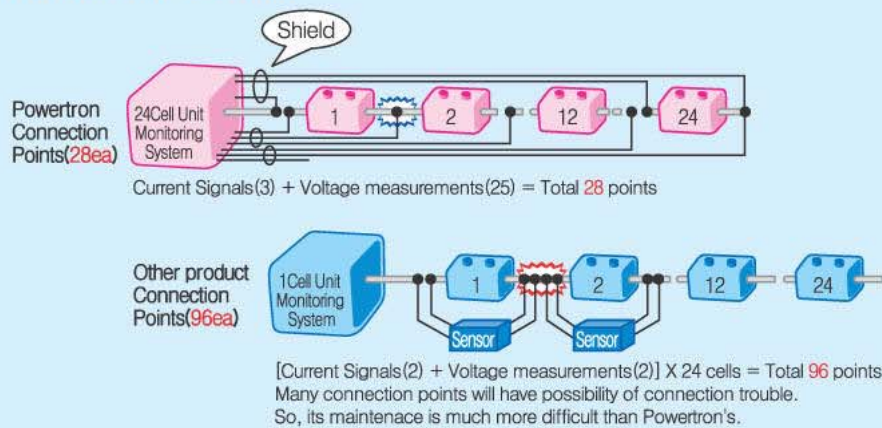

IPQMS/BDS Advantages

- iPQMS/BDS utilizes patented technology to identify early deterioration signs with all stationary applications by alarm, with enough time in advance to replace the failing batteries.
- Adopting the world's first ripple-removing algorithm(KR PAT No.0494489), the system precisely measures the RMS impedance value and the real properties of stationary batteries in floating charge with the precision of $\pm 2.0\%$.
- With a flexible expanding system, this system can supervise an emergency power supply lines and up to 448 cells of battery strings in real time with one monitoring/control unit. This reformative expansion capacity allows the user to arrange and install the whole system with ease, thus saving a great amount of installation expenses.
- iPQMS/BDS can directly transmit the data that are measured by intelligent instruments and communication software through TCP/IP ethernet, wireless and etc. as well as internet.
- When a voltage sag or power failure of emergency power lines occurs or the preset limits are exceeded, the event is transmitted to the administrator via SMS through a remote communication network such as CDMA.
- iPQMS/BDS offers the most comprehensive diagnosis software and reporting package
- iPQMS/BDS meets and exceeds all IEEE Std. recommendations

Centroid Web 2005 / 2008 (Monitored and recorded battery data)



- Display of voltage and ohmic impedance of each cells
- Display of AC, UPS/voltage of charger/current
- Display of recorded event waves

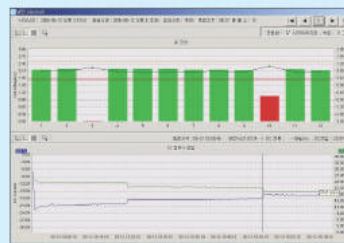

- Display of recorded each cell voltage during discharge.
- Display of bad cell voltage, how fast go down under voltage failure.

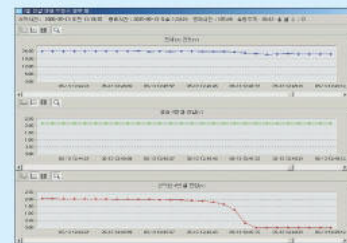

- Display of trended voltage data of string DC voltage, normal cell voltage and selected cell voltage.

Model Specifications

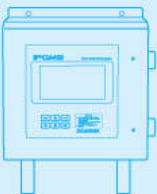

Model	iPQMS/BDS 64C-10	iPQMS/BDS 128C-10	iPQMS/BDS 448C-10	BDS/pro 24C-4	BDS/lgt
Cell numbers	Under 64 cells	Under 128 cells	Customized production by order	Under 24(48) cells	Under 4 cells
Option	1. Monitoring function of specific gravity, electrolyte level and surrounding temperature by additional sensor. 2. International standard emergency power quality monitoring: SEMI F47, CBEMA, ITIC, military, etc.				

Specifications and Characteristics

- | | |
|---|---|
| <ul style="list-style-type: none"> • Measurement Ranges <ul style="list-style-type: none"> - Capacity Range : 10 Ah ~ 6000 Ah max. (sealed/lead acid, Ni-Cd) - Cell or Unit Voltage : 0.1 Volts ~ 16.0 Volts - String DC Voltage/Current : 0V ~ 480V / 0A ~ 1,000A - AC voltage / AC current : 0V ~ 600V/5A (Current Transformer) • Measurement Accuracy <ul style="list-style-type: none"> - Cell or Unit ohmic impedance : $\pm 2\%$ - DC Voltage/Current : Voltage $\pm 0.5\%$ / Current $\pm 1\%$ - Temperature : $\pm 2\%$ • Resolution <ul style="list-style-type: none"> - Ohmic impedance : 0.001mΩ - Cell Voltage : 10mV - String DC Voltage/Current : 0V ~ 480V / 0A ~ 1,000A - Cell Temperature : 0.1$^{\circ}$C - AC Voltage / Amp : 0.1V / 1A • Measuring Interval : 4 minutes ~ 1 day (adjustable) • Data storage interval : 4 minutes ~ adjustable
 iPQMS/BDS: 90days of 64 cells X 1 measurement/day
 BDS/pro: 60days of 24 cells X 1 measurement/day | <ul style="list-style-type: none"> • Measuring Speed : 1sec/per cell • Data Transfer : RS232/422/485, TCP/IP, CDMA(option) • Other available functions <ul style="list-style-type: none"> - Auto Scaling functions - Zero point adjustment function - Exclusion of ripple voltage in floating charge - Measuring channel number selection • User Programmable Functions <ul style="list-style-type: none"> - Preset values for up to 448 cells - Display menu - Over/Under alarm setting : voltage, current and ohmic impedance - Year/Date/Time setting, display menu. • Environmental Operating Range <ul style="list-style-type: none"> - Temperature : -5°C ~ $+45^{\circ}$C - Humidity : under 95% RH • Remark <ul style="list-style-type: none"> - Capacity Range of BDS/pro : 10Ah ~ 3,000Ah, 2V/12V |
|---|---|

IBEX-series Intelligent Battery EXaminator Battery Quality Diagnostic Tester



Introduction

IBEX is a cutting-edge digital Battery quality diagnostic tester by all IEEE Std. recommendations for all the stationary applications such as telecommunication's backup power, utility switching power, uninterruptible power systems (UPS), etc and can measure the accurate internal ohmic measurement (R), voltage (V), temperature (°C) with the world's first ripple-removing algorithm(KR PAT No.0494489) within a short time(3 seconds or less) during floating charge.

Actually, we have provided them to Korea Telecom, SK Telecom, Korea Electric Power Corporation, Korea Railway Corporation, Storage Battery System in the US, KingCable in China and others with their utmost satisfaction and reliability of IBEX has been verified reliability verification tests of end-users, such as Korea Telecom Providers.

IBEX Advantages

- IBEX meets all IEEE Std. recommendations for all stationary battery systems.
- IBEX has a built-in type automatic measuring algorithm consisted of Normal(less than 4 seconds for measurement), Fine and Automatic, it automatically measures and stores data by contacting probes to the battery posts. Thus, it can measure a lot of cells in a short while.
- IBEX can manage the measuring data of batteries in 15 different types of bank strings and it enables effective data management, data transfer to PC and easy database operations.
- IBEX is the world's first compact and light weight tester(One hand hold size), it is advantageous for on-road measurement.
- To make it more user friendly, most of its menu items are displayed in the form of icons so that even a beginner can use it without difficulty.
- Even when battery shorted with inside plates, IBEX enables to measure the battery cell that has lower value than 0.5V and also can measure its intercell resistance easily and instantly.
- IBEX uses a Li-ion battery to increase use time(Over 4 hours) and is marked by an enhanced durability with the elimination of moving part
- IBEX offers the most comprehensive diagnosis software (Exmons Pro 2005 / 2008) and reporting package.



Exmons Pro 2005 / 2008 (Diagnosis Software)

- Exmons is a comprehensive diagnosis software to ensure the integrity of your backup batteries and any power backup systems.
- By constructing database of the measuring data, it can be stored and managed as a site-specific tree structure in the PC.
- Exmons provides handy information such as a battery cell's deterioration displayed in a range of graphs as well as various screen menus, it allows users to analyze and determine the aging status of battery in a highly user-friendly environment.
- Exmons has a bank-specific report printout function, it frees users from the manual documentation and allows them to utilize the analysis outcomes.
- By saving the measuring data in excel file, Exmons facilitates documentation of the data.
- Trended battery measurement data can detect impending battery failures before power backup system is affected, with enough time in advance to replace the failing batteries.
- Exmons Pro 2008 supports a multi-user environment in data management.

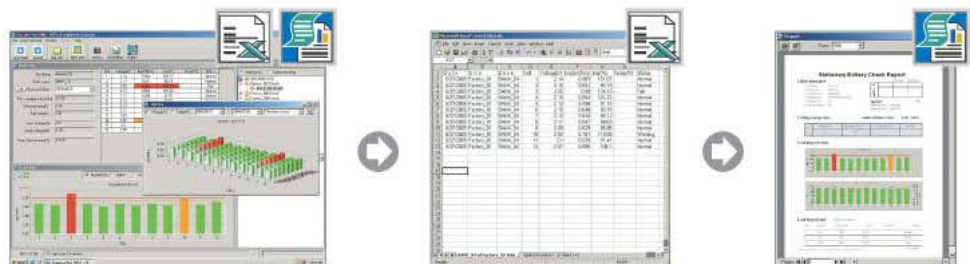

IBEX out line view

IBEX 1000 / PRO



Equipment and Accessories



MODEL	EQUIPMENT AND ACCESSORIES
IBEX-1000	IBEX-1000(main body), Soft Poly-Vinyl Bag(for storage or measurement), Charger(220V AC Standard Charger for Body), Pin Probe(4-Point Pin type), SerialComm(Bundled Software)
IBEX-PRO	IBEX Pro(main body), Thermal Printer, Soft Poly-Vinyl Bag(for storage or measurement), Charger(220V AC Standard Charger for Body), Pin Probe(4-Point Pin type), Clip Probe, Temperature Probe, Exmons Pro 2005(Diagnosis Software), Portable Carrying Case(450Wx340Dx120H), Spare Li-ion Battery Pack, Spare 4-pin Tip, Shunt(50mV/50A, 1m Ω)

Specifications and Characteristics

- | | |
|---|--|
| <ul style="list-style-type: none"> • Exterior size and weight (Except the measuring lead) <ul style="list-style-type: none"> – 95W×42D×175H, less than 650g (including internal battery) • Measurement ranges <ul style="list-style-type: none"> – 10 Ah~ 6000 Ah max., 1.0Volt ~ 60Volt DC • Measurement Accuracy <ul style="list-style-type: none"> – Voltage : ± 0.5 class – Temperature : ± 2 class ($-20^{\circ} \sim +80^{\circ}$) – Ohmic impedance : $\pm 1.0\%$ rdg. ± 8dgt. (3milli ohm full-scale) across test range • Resolution <ul style="list-style-type: none"> – Ohmic impedance : 0.001mΩ – DC voltage : 10mV – Temperature : 0.5$^{\circ}$C • User Programmable <ul style="list-style-type: none"> – Over/Under Voltage alarm setting – Fail/Warning Impedance alarm setting – Over Temperature alarm setting – Display menu | <ul style="list-style-type: none"> • Other available functions <ul style="list-style-type: none"> – Auto scaling function – Zero point adjustment function – USB serial Port – Measured data storage capacity : Choose from 15 different modes including • Exmons Pro 2005 / 2008 : <ul style="list-style-type: none"> – Integrated diagnostic software of stationary applications – Database construction and control by site/bank/cell – 2D graph display of changes against basic value – 3D graph display of changes by period – Printing of data and analysis report including graph – Prohibition of data modification • Communication Protocol : Binary or Standard ASCII Text • Data Format : Excel 2000/2002 and Windows 98/2000/XP/Vista Compatible • Built-in Battery : Li-ion Battery (1950mAh, 11.1V) • Charging Ripple Current content percent(%) analysis |
|---|--|



KR PAT 0494489



KR PAT 0546246



CE Certification
of IBEX



CE Certification
of iPQMS



Certificate of New
Excellent Product



Certificate of Excellent
Quality Product



ISO 9001

Conventional Methods

While conventional methods of diagnosis of power backup batteries or stationary battery systems have been made by discharge testing to obtain meaningful information, especially with flooded (wet) cell or large VRLA battery systems.

With the IBEX and iPQMS there is no longer a need for frequent discharge test, specific gravity tests, and intercell resistance testing.

New technology

Adopting the world's first ripple-removing algorithm (KR PAT No.0494489),

POWERTRON's IBEX and iPQMS with all IEEE standard recommendations allow the user to diagnose the aging status of any battery quickly, safely and simply by impedance measuring technology in floating charge.

And reliability of the IBEX and iPQMS have been verified by diverse certifications, such as CE, Patents, KT approval (Excellent Korean Technology), ISO quality certification system and reliability verification tests of end-users, such as Korea Electric Power Corporation, Korea Telecom providers and Korea Railway Corporation.

Battery Expected Life Correlation between internal ohmic measurement and capacity

- A 30% rise in internal ohmic measurement above the reference value roughly equates to 80% battery capacity, which is the point at which the IEEE recommends immediate corrective action or replacement. Based on these recommendations, POWERTRON has adopted the 30% ~ 50% value as the critical internal impedance alarm point.
- POWERTRON recommends to replace the battery for protecting your stationary battery system as the aging status of the battery is unpredictable as ΔT displayed on the graph after this 80% capacity point is reached.
- We believe that the only way to ensure the integrity of your VRLA battery system by IEEE recommends is to replace the bad battery in the string when the internal ohmic measurement rises over 30%.

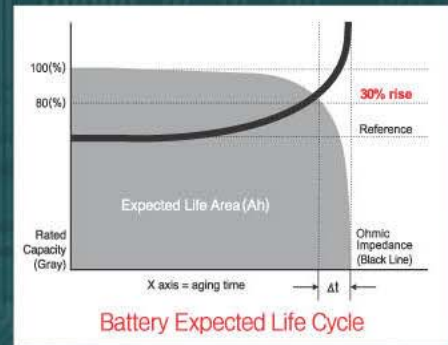

WORLDWIDE HEADQUARTERS

639, Irwon-dong, Kangnam-gu, Seoul, 135-230, Korea
 TEL: +82-2-445-5787-9 FAX: +82-2-451-1852

FACTORY

718-4, Baekseok-dong, Cheonan-si,
 Chungcheongnam-do, Korea
 TEL: +82-41-563-0985 FAX: +82-41-564-0984

www.powertron.co.kr / sales@powertron.co.kr

* The content of this information is subjected to change without prior notice for the improvement of the products performance.